



FLOWN WIRE SYSTEMS

CAMCAT® 2D

The CAMCAT® 2D, a variant of the CAMCAT® Standard, is an advanced, fully remote controlled cable camera system designed to provide two dimensional camera movement, vertical and horizontal, between two fixed points up to 350m apart at speeds of up to 54 km/h

The CAMCAT® 2D can accept a range of payloads including platform stabilised mounts fitted with different camera types up to 35mm or IMAX, as well as stabilised mounts with integrated camera and lens.

Compatible open platform stabilised mounts include:
Libra Head, Scorpio Head, Stab-C Compact, Mini-C and Flight Head.

Compatible stabilised mounts with integrated camera and lens include:
Wescam and Cineflex.



Technical Specifications

MAXIMUM SPEED HORIZONTAL:	54km/h, 15m/s (34 mph)
MAXIMUM SPEED VERTICAL:	18km/h (11 mph)
MAXIMUM PAYLOAD:	100KG (220lbs)
LENGTH:	Standard length up to 350m (1148ft) Longer length by request
DIMENSIONS (Base):	Length: 5m (16.4ft) Height: 4.5m (14.7ft) Width: 2.6m (8.5ft) Weight: 1600KG (3500lbs)
POWER SUPPLY:	2 x power current (3 x 400 volt) 2 x 32 Amp

Certified by the German Health & Safety Group (TUV) including BGVC1

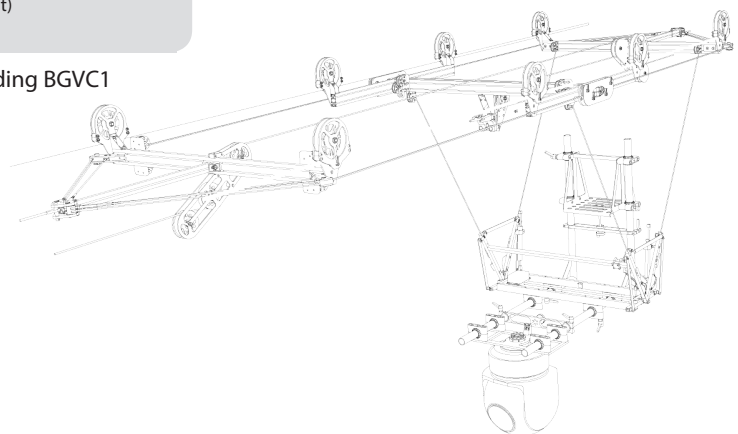

Developed by CAMCAT Systems GmbH and operated in co-operation with ACS



CAMCAT-SYSTEMS GMBH

t: +44 (0)1483 462767 e: enquiries@acsmedia.com w: acsmedia.com

