

ICONIX HD-RH1

Perfect for a wide range of POV applications, the Iconix HD-RH1 is a state of the art High Definition miniature camera system providing impressive functionality and performance in a compact package. The camera head incorporates a 1/3 inch progressive CCD image sensor offering the versatility of 720p, 1080i, 1080p, 480i (NTSC) and 576i (PAL) at all standard frame rates.

The camera is supplied as standard with three C-Mount lens options - 2.8mm, 4mm and 8mm and a variety of mounts are available including an underwater housing. For standalone production work the camera can be supplied with a range of portable recorder options (HDCAM & HD DVC Pro). For live applications from Sport to Music to Entertainment, the Iconix can be integrated with the unique ACS fibre transmission system allowing video and camera/iris control via an RCP over single mode of SMPTE fibre with seamless integration into an Outside Broadcast environment.

Technical Specifications

IMAGE SENSOR:	1/3 inch progressive CCD
OPTICAL SYSTEM:	1/3 inch 3 CCD Prism system
LIMITING RESOLUTION:	900 TV Lines (1080i/p), 700 TV Lines (720p)
LENS MOUNT:	C-Mount
SCANNING SYSTEMS:	720p/23.98, 24,25,29.97,30,50,59.94,60Hz 1080i/50,59.94,60Hz 1080p/23.98,24,25,29.97,30,50,59.94,60Hz
SENSITIVITY:	f8/2000 lux
SIGNAL/NOISE RADIO:	>60dB, Y Channel
QUANTIZATION PROCESSING:	14-Bit
GAMMA:	On/Off, five variable user adjustable
WHITE BALANCE:	Automatic (AWB) or manual
BLACK BALANCE:	Automatic
GAIN:	0dB to 18dB, manual or fixed



ELECTRONIC SHUTTER:	Automatic or fixed
SCENE FILE:	3 user programmable profiles
SYNC SYSTEMS:	Internal or genlock to tri-level sync
OUTPUT SIGNALS:	RGB/YpPr.BNC x 3, 1 Vpp, 75Ohm Sync on Y/G or YpPr/RGB HD-SDI (SMPTE-292M): BNC x 2 Two single link 4:2:2 or dual link 4:4:4 (RGB or YpPr) or dual link 4:2:2 (1080p50/60) DVI-D

Technical Specifications - continued

INPUT SIGNALS: Genlock: BNC x 1, Tri-level Synce
 Audio signal: XLR3 x 1, 1-Channel Balanced
 60, -50, -40, -30, -20, -10, 0, +4dB 600-Ohm
 Remote control: RS-232, DSUB-9

POWER REQUIREMENTS: 12VDC, 30W

WEIGHT: Head: 64g (2.3oz) Controller: 1.2KG (2.6lbs)

DIMENSIONS: Head: 1.32W x 1.50H x 1.92"D (33.5 x 38 x 48.8mm)
 Controller: 8.4W x 1.78H x 12"D (213 x 45 x 305mm)

STANDARD CABLE LENGTH: 10 metre

TRIPOD MOUNT: Optional adapter for head with 1/-20 thread)

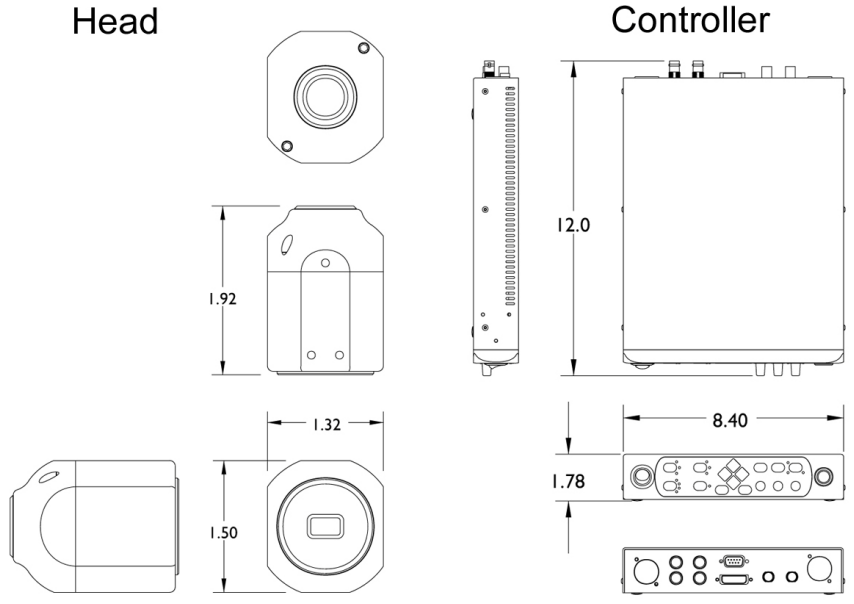

Cameras & Recorders

