

## CAMCAT HIGH SPEED

The CAMCAT High Speed, a variant of the CAMCAT LV, is an advanced, fully remote controlled cable camera system designed to run between two fixed points up to 750m apart at speeds of up to 130km/hour, providing unique and stunning images from an otherwise unobtainable perspective. The CAMCAT High Speed camera buggy can accept a range of payloads from open platform stabilised mounts fitted with film cameras to HD stabilised mounts with integrated camera and lens. The latest RF technology is utilised for picture transmission, camera and head control data to and from the camera buggy and the onboard battery power provides seamless operation for a typical period of two hours.

As with any system of this nature, safety factors have been prioritised at all stages of the system development with the utilisation of comprehensive electronic and software safety measures as well as the provision of two independent guide ropes made of advanced Spectra/Dyneema material. This has ensured full safety certification for the installation and operation of CAMCAT High Speed from the German based TUV Health and Safety Group, one of the strictest industrial safety authorities in the world.

Further information available on request. Developed by  
CamCat-Systems GmbH and operated in cooperation with ACS.

**CAMCAT®**  
CAMCAT-SYSTEMS GMBH



Flown Wire Systems

## Technical Specifications

<b>MAXIMUM SPEED:</b>	130km/h, 36, 1m/s, 80mph 5 seconds or 70m to 100km/h 6.4 seconds or 111m to top speed
<b>MAXIMUM ACCELERATION LENGTH:</b>	5.5m/s <sup>2</sup> Standard length up to 750m/2460ft Longer length by request
<b>DIMENSIONS:</b>	<b>Length:</b> 5m (16.4ft) <b>Height:</b> 4.5m (14.7ft) <b>Width:</b> 2.6m (8.5ft) <b>Weight:</b> 1600KG (1433 lbs)
<b>POWER SUPPLY:</b>	2 x Power current (3 x 400 volt) - 2 x 32 Ampere
<b>PROOF OF STATIC:</b>	Doc. No 98 RIH 42/907

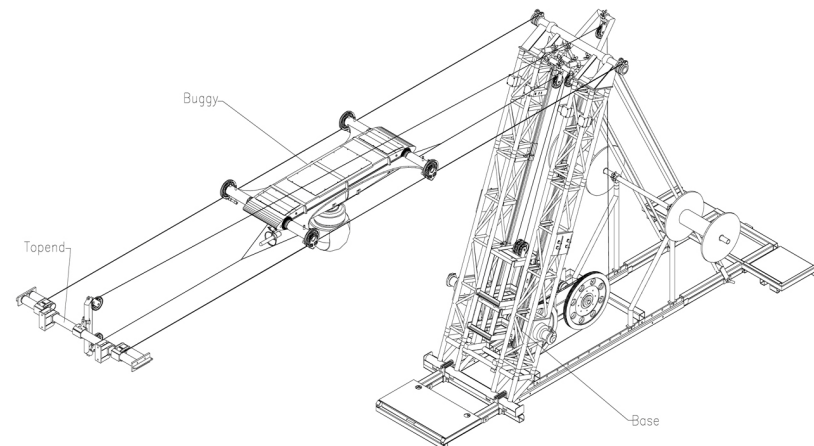

AERIAL CAMERA SYSTEMS LIMITED

TEL: +44 (0)1483 462767 E-MAIL: info@acsmedia.com WEB: www.acsmedia.com

